

G-15M-3

Single-Phase



General data

Maximum power*:	15 kW (15 kVA)	Voltage:	230 V
Prime Power**:	13,6 kW	Amperage:	65,2 A
Frequency:	50 Hz	Phases:	1

Dimensions and weights

Total length without canopy:	1023 mm	Total length with canopy:	- mm
Total width without canopy:	500 mm	Total width with canopy:	- mm
Total height without canopy:	588 mm	Total height with canopy:	- mm
Dry weight without canopy:	225 Kg	Dry weight with canopy:	- Kg

Engine

Base engine manufacturer:	Mitsubishi	Diameter:	76 mm (2,99 in)
Model Solé Diesel:	MINI-26	Stroke:	70 mm (2,76 in)
Type:	4 No. of Strokes	Compression ratio:	23:1
Engine RPM:	3000	Injection system:	Mechanical and indirect
Number of cylinders:	3	Intake system:	Naturally aspirated
Total displacement:	952 cc	SAE Flywheel housing:	SAE 5
Oil type:	SAE 15W40	Coolant capacity:	3 L (0,79 gal)
Oil capacity:	4 L (1,06 gal)	Flywheel:	SAE 6 1/2
Power:	16,3 kW (22,17 CV)	Coolant flow rate:	43 l/min (11,36 gal/m)
Salt water flow rate:	29,5 l/min (7,79 gal/m)	Intake air flow rate:	1,32 m ³ /m
Exhaust type:	Wet exhaust elbow	Belt protection:	Optional

Rating conditions according to ISO 3046 (100 kPa barometric pressure, 30 % relative humidity and 25 °C (77 ° F))

* Maximum output power: maximum power supplied by the genset at full load

** Prime Power: rated power according to ISO 3046 and ISO 8528-1. 10 % overload capacity one hour in twelve hours.

1 kW \cong 1,36 CV 1 kW \cong 1,36 HP (metric) 1 kW \cong 1,36 CH

Fuel system details

Consumption 25%:	1,7 L/H (0,45 Gal/H)	Fuel type:	Diesel
Consumption 50%:	3 L/H (0,79 Gal/H)	Fuel standards:	Fueloil diesel ASTM
Consumption 75%:	4,1 L/H (1,08 Gal/H)	Injection pump type:	In line
Consumption 100%:	5 L/H (1,32 Gal/H)	Governor type:	Mechanical

Electrical system

Battery voltage:	12 V	Stop solenoid type:	ETR
Starter motor:	1,2 kW	Alternator:	40 A
Earth isolated:	Optional	IP 65 box kit:	Optional
#N/D	Optional	Current transformers:	Optional

Installation details

Exhaust hose inner diameter:	50 mm (1,97 in)	Maximum fuel lift height:	0,3 m (0,98 ft)
Sea water hose inner diameter:	20 mm (0,79 in)	Maximum raw water lift height:	2,5 m (98,43 in)
Fuel feeding hose inner diameter:	8 mm (0,31 in)	Maximum sea water temperature:	32 °C (89,6 °F)
Fuel return hose inner diameter:	6 mm (0,24 in)	Maximum installation angle***:	25 °
Minimum battery capacity:	12 V 60 Ah		

Alternator details

Brand:	Meccalte	Cos φ:	0,8
Model:	ECP-28 2L/2	Tropicalized:	Yes
Regulator type:	DSR	Excitation system:	BRUSHLESS
Number of poles:	2	Voltage regulation accuracy**:	1%
Isolation type*:	H	Standards:	EN60034-1, IEC 60034-1
IP protection*:	23	Alternator type:	Synchronous

Standard equipment

4 m electrical wiring extension	SCO 5 control panel
Oil extraction pump	Owner's and alternator manual
Rigid bed	Packaging
Silentblocks	

Optional accessories

Siphon break kit mandatory if generator is below waterline	Keel Cooling conversion for dry and wet exhaust
Engine electrical system at 24 V	Double walled pipes and alarm kit
Service/Cruise Kits: fuel and oil filters, raw water pump, impeller, alternator belt,...	Low coolant level shut down switch
Dry Exhaust system	Fuel filter/water separator
Wet Exhaust System	Gas/Water Separator
Water Filters	Fuel Hose
Sea water cock	Exhaust Hose
Welcome Kit	Raw water hose

* Other protections available

** With load from 0 to 100%, speed variation from -2% up to +5%, power factor 0,8 linear and balanced load.

*** In all directions

For other requirements please contact the Sales Dept.



SCO 5 Panel



General Description

- Graphic LCD with light Display, 128 x 64 pixels
- 3 LED indicators
- Marine genset measures (see display information)
- Marine genset protections (see alarm management)
- Running hour indicator
- Type B USB for programming
- Programming from the same panel
- Universal Interface
- Preheating function
- D+ preexcitation terminal
- CAN bus output with SAEJ1939 protocol
- 2 multipurpose timers
- Dimensions 118x 108 x 43 mm
- Weight 246 g

Alarm Management

Shutdown (SD)

- High coolant temperature
- Low oil pressure
- Overspeed
- Overload*
- Short circuit*
- Overcurrent*
- Over/Under voltage
- Over/Under frequency
- Emergency stop

Warnings (WRN)

- Over/Under battery voltage
- Maintenance request

Sensor Fails (FLS)

Power Supply

- Voltage supply 12/24 DC with fuse protection
- Consumption 60/35 mA

Operating Conditions

- Operating temperature -20+70 °C
- Humidity 95 % Without condensation
- Front Panel Protection IP65

Standard Conformity

- Low Voltage Directive EN 61010-1:95+A1:97
- Electromagnetic EN 50081-1:94, EN 50081-2:96
- Compatibility EN 50082-1:99, EN 50082-2:97

Display Information

Measurement

- L1-L3 Voltage (V), Frequency (Hz), Oil Pressure, (bar)
- Coolant Temperature (°C), Battery, Voltage (V), RPM
- Active Power* (kW), Apparent, Power* (kVA), Current* (A), PF*

History log

Function Description

- OFF Mode
- MAN Mode (manual start/stop engine)
- AUT Mode (auto start/stop engine)



* The specified function needs the current transformers (Optional Equipment) for showing the information in panel display.

Dimensions

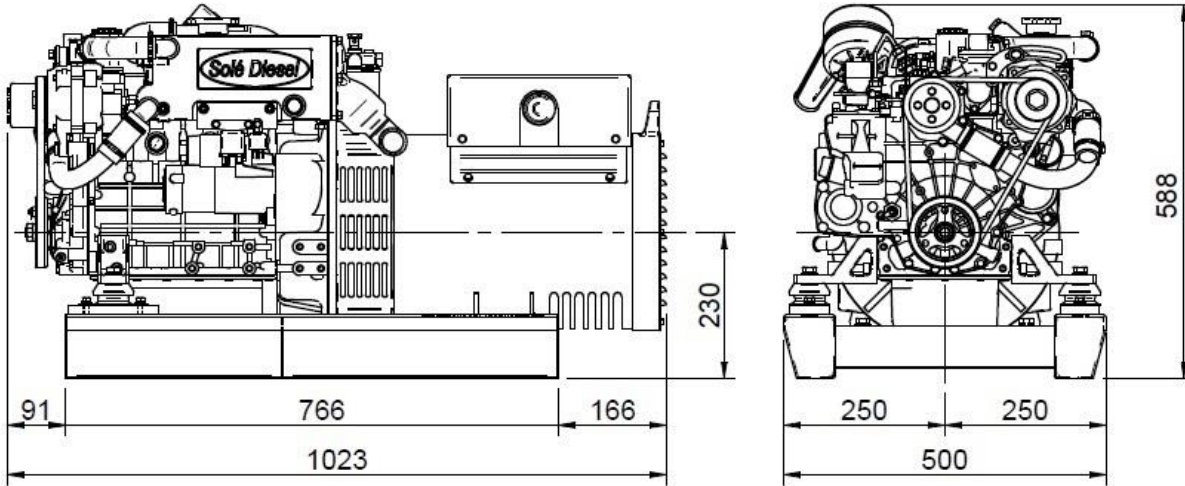

Authorized dealer

www.solediesel.com
info@solediesel.com

Detailed drawings, brochures and manuals are available on the web [solediesel.com](http://www.solediesel.com). All rights reserved. Technical specifications, data and presentation are subjected to variations, changes and updates without prior notice. Non-contractual information.