

MARINE GENERATORS

45 GT/GTC

Three-Phase



General data

Maximum power*:	36 kW (45 kVA)	Voltage:	400/230 V
Prime Power**:	32,7 kW	Amperage:	65 A
Frequency:	50 Hz	Phases:	3

Dimensions and weights

Total length without canopy:	1428 mm	Total length with canopy:	1605 mm
Total width without canopy:	740 mm	Total width with canopy:	740 mm
Total height without canopy:	785 mm	Total height with canopy:	841 mm
Dry weight without canopy:	560 Kg	Dry weight with canopy:	598 Kg

Engine

Base engine manufacturer:	Mitsubishi	Diameter:	94 mm (3,7 in)
Model Solé Diesel:	SM-56	Stroke:	120 mm (4,72 in)
Type:	4 No. of Strokes	Compression ratio:	17:1
Engine RPM:	1500	Injection system:	Mechanical and direct
Number of cylinders:	4	Intake system:	Turbocharged
Total displacement:	3331 cc	SAE Flywheel housing:	SAE 3
Oil:	SAE 15W40	Coolant capacity:	13 L (3,43 gal)
Oil capacity:	10 L (2,64 gal)	Flywheel:	SAE 11 1/2
Power:	40,5 kW (55,08 CV)	Coolant flow rate:	105 l/min (27,74 gal/m)
Salt water flow rate:	38 l/min (10,04 gal/m)	Intake air flow rate:	2,9 m3/m
Exhaust type:	Wet exhaust elbow	Belt protection:	Optional

Rating conditions according to ISO 3046 (100 kPa barometric pressure, 30 % relative humidity and 25 °C (77 ° F))

* Maximum output power: maximum power supplied by the genset at full load

** Prime Power: rated power according to ISO 3046 and ISO 8528-1. 10 % overload capacity one hour in twelve hours.

1 kW \cong 1,36 CV 1 kW \cong 1,36 HP (metric) 1 kW \cong 1,36 CH

Fuel system details

Consumption 25%:	3,2 L/H (0,85 Gal/H)	Fuel type:	Diesel
Consumption 50%:	5,2 L/H (1,37 Gal/H)	Fuel standards:	Fueloil diesel ASTM
Consumption 75%:	7,4 L/H (1,95 Gal/H)	Injection pump type:	In line
Consumption 100%:	9,7 L/H (2,56 Gal/H)	Governor type:	Mechanical

Electrical system

Battery voltage:	12 V	Stop solenoid type:	ETR
Starter motor:	2,2 kW	Alternator:	50 A
Earth isolated:	Included	IP 65 box kit:	Optional
SCO 11 double panel:	Optional	Current transformers:	Included

Installation details

Exhaust hose inner diameter:	75 mm (2,95 in)	Maximum fuel lift height:	0,3 m (0,98 ft)
Sea water hose inner diameter:	32 mm (1,26 in)	Maximum raw water lift height:	2,5 m (98,43 in)
Fuel feeding hose inner diameter:	8 mm (0,31 in)	Maximum sea water temperature:	32 °C (89,6 °F)
Fuel return hose inner diameter:	8 mm (0,31 in)	Maximum installation angle***:	15 °
Minimum battery capacity:	12 V 95 Ah		

Alternator details

Brand:	Meccalte	Cos φ:	0,8
Model:	ECP32 1M 4 C	Tropicalized:	Yes
Regulator type:	DSR	Excitation system:	BRUSHLESS
Number of poles:	4	Voltage regulation accuracy**:	0,01
Isolation type*:	H	Standards:	EN60034-1, IEC 60034-1
IP protection*:	23	Alternator type:	Synchronous

Standard equipment

Earth isolated	Silentblocks
Amperometric transmitter kit	SCO 10 control panel
4 m electrical wiring extension	Owner`s and alternator manual
Oil extraction pump	Packaging
Rigid bed	

Optional accessories

Siphon break kit mandatory if generator is below waterline	Keel Cooling conversion for dry and wet exhaust
Engine electrical system at 24 V	Double walled pipes and alarm kit
Service/Cruise Kits: fuel and oil filters, raw water pump, impeller, alternator belt,..	Low coolant level shut down switch
Dry Exhaust system	Fuel filter/water separator
Wet Exhaust System	Gas/Water Separator
Water Filters	Fuel Hose
Sea water cock	Exhaust Hose
Welcome Kit	Raw water hose

* Other protections available

** With load from 0 to 100%, speed variation from -2% up to +5%, power factor 0,8 linear and balanced load.

*** In all directions

For other requirements please contact the Sales Dept.



SCO 11 Panel



General Description

- Graphic LCD with light, 128 x 64 pixels display
- Genset measures (see Display Information)
- Configuration protected by user and password
- Running hour indication
- Multilengüaje
- Event history log
- Genset protections (see Alarm Management)
- Preheating function
- D+ pre-excitation Terminal
- CAN bus information with SAE J1939 protocol
- Maintenance hours control
- Dimensions 195 x 135 x 47 mm
- Board Cutting 172 x 112 mm
- Weight 450 g

Alarm Management

Shut Downs (SD)

- High coolant temperature
- Low oil pressure
- Overspeed
- Overload*
- Short circuit*
- Overcurrent*
- Over/Under voltage
- Over/Under frequency
- Emergency stop

Warnings (WRN)

- High coolant temperature
- Low oil pressure
- Over/Under Battery voltage
- Maintenance request
- Sensor failure detection (FLS)

Operating modes

- OFF Mode
- MAN Mode (manual start/stop engine)
- AUT Mode (auto start/stop engine)



Power Supply

- Voltage supply 12/24 DC with fuse protection
- Consumption 80mA (12V) or 51 (24V)

Operating Conditions

- Operating temperature -20+70 °C
- Humidity 95 % without condensation
- Front Panel Protection IP65

Standard Conformity

- EN 61000-6-2, EN 61000-6-4, EN 61010-1
- EN 60068-2-6 (2÷25 Hz / ±1,6 mm; 25÷100 Hz / 4.0 g)
- EN 60068-2-30:2005 25/55 °C, RH 95%, 48hours
- EN 60529 (front panel IP65, back side IP20)

Display Information

Measurement

- L1-L3 Voltage (V), Frequency (Hz), Oil Pressure (bar)
- Coolant Temperature (°C), Battery voltage (V), RPM
- Active Power* (kW), Apparent, Power* (kVA), Current* (A), PF*

History log

Optional Equipment

- RS232-485 module for double danel
- Binary Inputs/Outputs extension module
- IG-IB Internet connection bridge
- IP65 metallic box protection kit

* The specified function needs the current transformers (Optional Equipment) for showing the information in panel display.

Dimensions

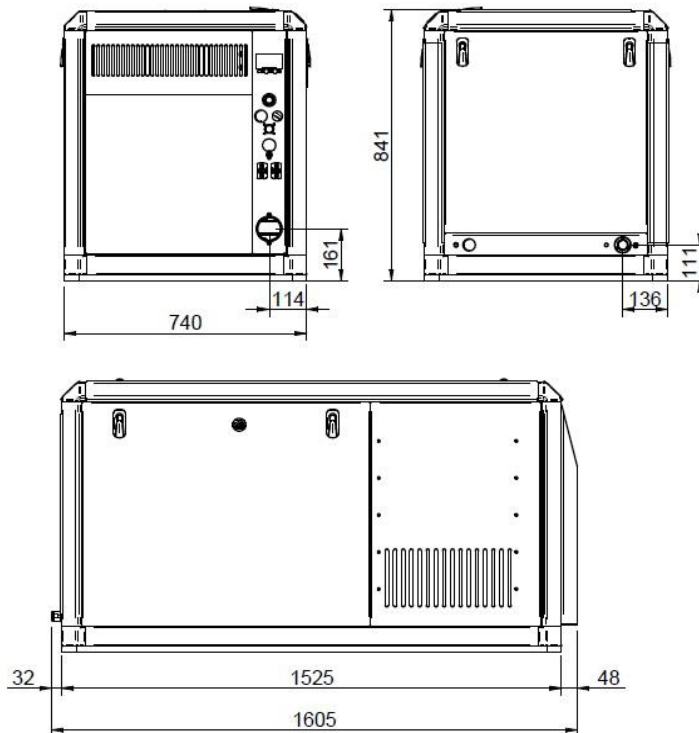
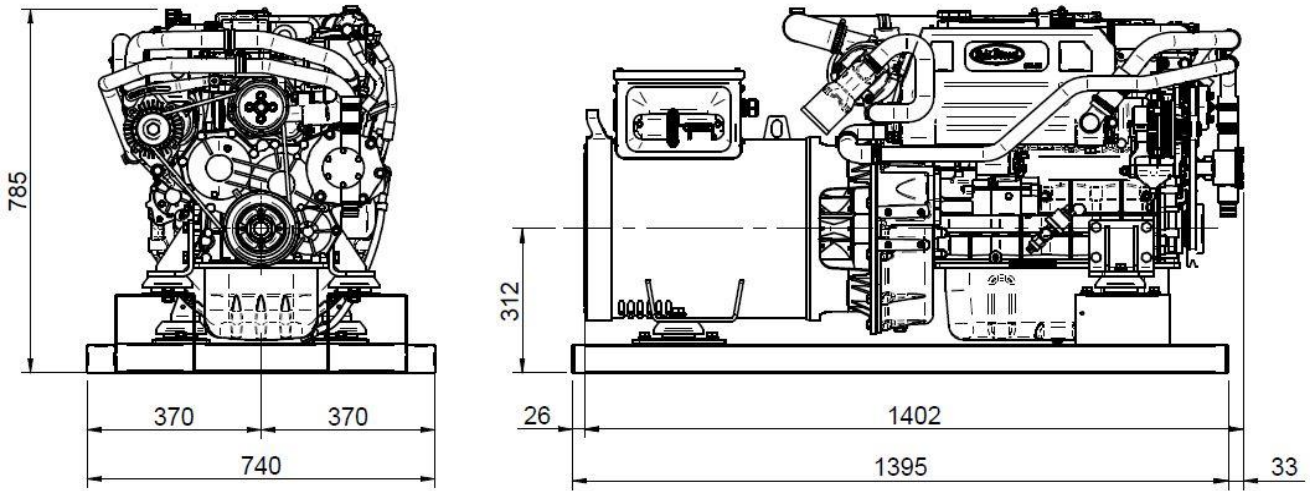

Authorized dealer

www.solediesel.com
info@solediesel.com

Detailed drawings, brochures and manuals are available on the web [solediesel.com](http://www.solediesel.com). All rights reserved. Technical specifications, data and presentation are subjected to variations, changes and updates without prior notice. Non-contractual information.